



# PATTERSON SERVICES, INC.

**Tubing**  
1" thru 4 1/2"

**Drill Pipe**  
2 3/8" thru 5 1/2"

**Heavy Weight  
Drill Pipe**  
2 7/8" thru  
6 5/8"

**Drill Collars**  
2 7/8" thru 10"

**Blow-Out  
Preventers**  
**Annular Type**  
2 9/16" 5M thru  
29 1/2" 500 PSI

**Hydraulic Ram  
Type**  
**Single and Double**  
3 1/16" 10M thru  
21 3/4" 5M

**Valves Manual &  
Hydraulic**  
12" Ball Valves  
2 1/16" 5M thru  
4 1/16" 15M

## BOP Information Sheet\*

## Hydril GK Annular BOP 11" 5K

1	BOP Serial #	P-
2	Type	GK 11" 5K Annular BOP
3	Manufacturer	Hydril
4	Height	47.8125" / 1.214 m
5	Weight (Approximate -- varies with connectors)	8,200 lbs. / 3,720 kilograms
6	Clearance Diameter	44.250" / 1.120 m
7	Hydraulic operating pressure	≤ 1,500 PSI / 103.422 bar
8	Max hydraulic pressure	1,500 PSI / 103.422 bar
9	Open port and Close port size	1" NPT
10	Open volume	7.98 U.S. Gallons / 30.208 Liters
11	Close volume	9.81 U.S. Gallons / 37.324 Liters
12	11" 5K Studded Top Bolts Diameter x Length	1-7/8" x 9-5/8" / 47.625 mm x 244.475 mm
13	Quantity	12 per studded flange
14	Bolt Torque	3,332 ft-lbs / 4,518 N'm
15	11" 5K Flanged Bottom Bolts Diameter x Length	1-7/8" x 14-1/4" / 47.625 mm x 374.650 mm
16	Quantity	12 per flange
17	Bolt Torque	3,332 ft-lbs / 4,518 N'm
18	Flange Gasket (Open-faced Bottom Flange)	R-54/RX-54
19	Studded Flange Gasket	R-54/RX-54
20	Lifting Capacity B.O.P. Lugs	

\* Drawings and information contained herein are for general purposes and are for reference only. Dimensions may vary according to Manufacturer, Year Manufactured, Model or Type.

Technical information contained herein is furnished without charge or obligation and is given and accepted at recipient's sole risk. Because conditions of use may vary and are beyond our control, Patterson Services, Inc. makes no representation about, and is not responsible or liable for the accuracy or reliability of the data, described herein. Nothing contained in this document shall be considered a recommendation for any use that may infringe patent rights, or an endorsement of any particular material, equipment, service, or other item. The properties listed in this document are not specification. They are provided as information only and in no way modify, amend, enlarge or create any specification or warranty.





# PATTERSON SERVICES, INC.

- Tubing**  
1" thru 4 1/2"
- Drill Pipe**  
2 3/8" thru 5 1/2"
- Heavy Weight Drill Pipe**  
2 7/8" thru 6 5/8"
- Drill Collars**  
2 7/8" thru 10"
- Blow-Out Preventers**  
Annular Type  
2 9/16" 5M thru 29 1/2" 500 PSI
- Hydraulic Ram Type**  
Single and Double  
3 1/16" 10M thru 21 3/4" 5M
- Valves Manual & Hydraulic**  
12" Ball Valves  
2 1/16" 5M thru 4 1/16" 15M

## SPECIFICATIONS

DIMENSIONAL DATA			Hydril GK Annular BOP 11" 5K
Size	Pressure rating (PSI)	Vertical Bore (inches)	Single Approx.* Weight (lbs)
11"	5,000	11"	8,200.00

\*Approximate: Varies with connectors.

The capital letters in the following designations refer to the BOP dimensional views and dimensional charts shown.

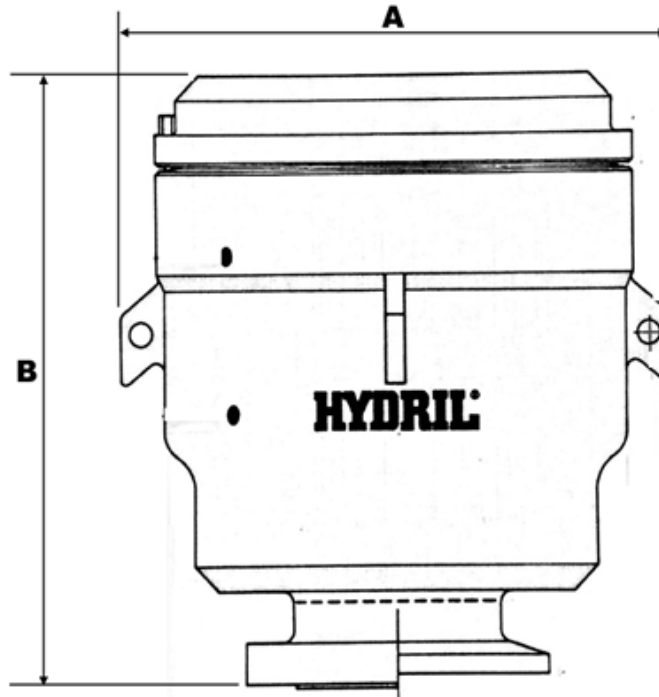

English Units (inches)		English Units (lbs)
A (Clearance Diameter)	B (height)	
44.250	47.813	8,200.000
Metric Units (m)		Metric Units (kgs)
A (Clearance Diameter)	B (height)	
1.124	1.214	3,720.000